



From Aircraft Availability
to
FIFTY SHADES
OF GREY WATER

18th October 2016
L.B.Newnes@Bath.ac.uk

Professor Linda Newnes - University of Bath
Dr Ettore Settanni - University of Cambridge
Mr Jon Wright - Wessex Water
Mr David Peacock – Wessex Water

Overview

From defence to the water sector and beyond...

- Our approach - Costing for Availability
- Why a systems based approach
- Defence application
- Waste Water application
- Wrap up

COSTING FOR AVAILABILITY

From defence to water sector ...and beyond?

Availability-based contracts



<http://www.guernseymodelclub.com>



<http://www.defenseprocurementnews.com/>



<http://3.bp.blogspot.com>

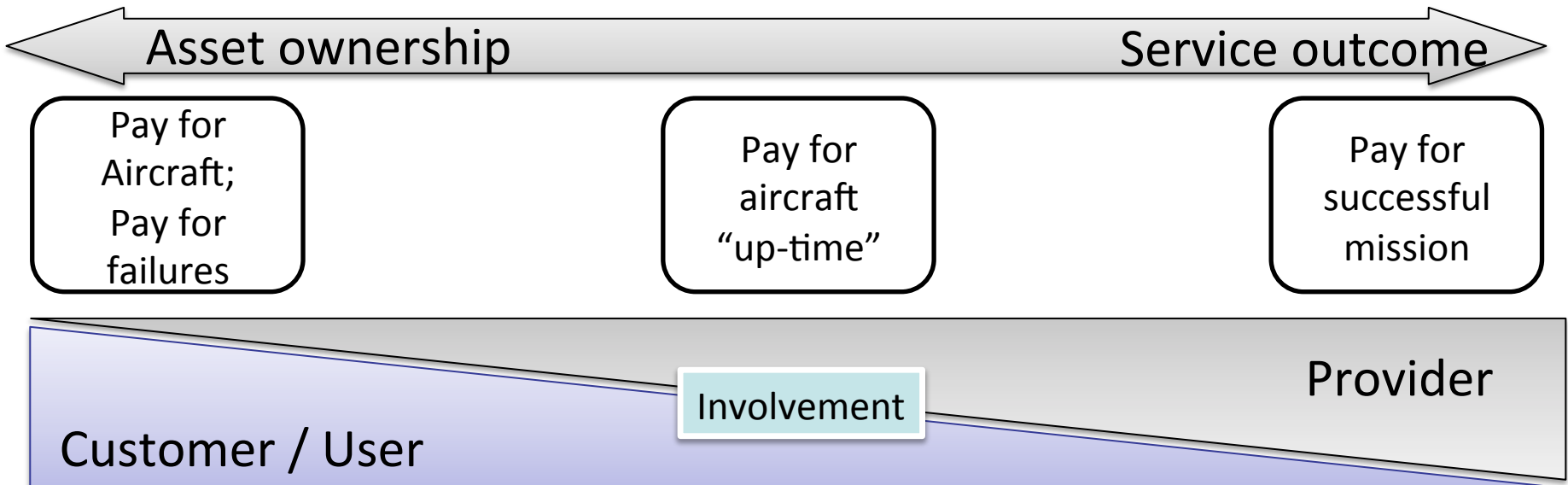

Asset ownership

Service outcome

Pay for Aircraft;
Pay for failures

Pay for aircraft
"up-time"

Pay for successful mission

Customer / User

Involvement

Provider

How availability can be interpreted

Reliability, Availability, Maintainability (RAM)

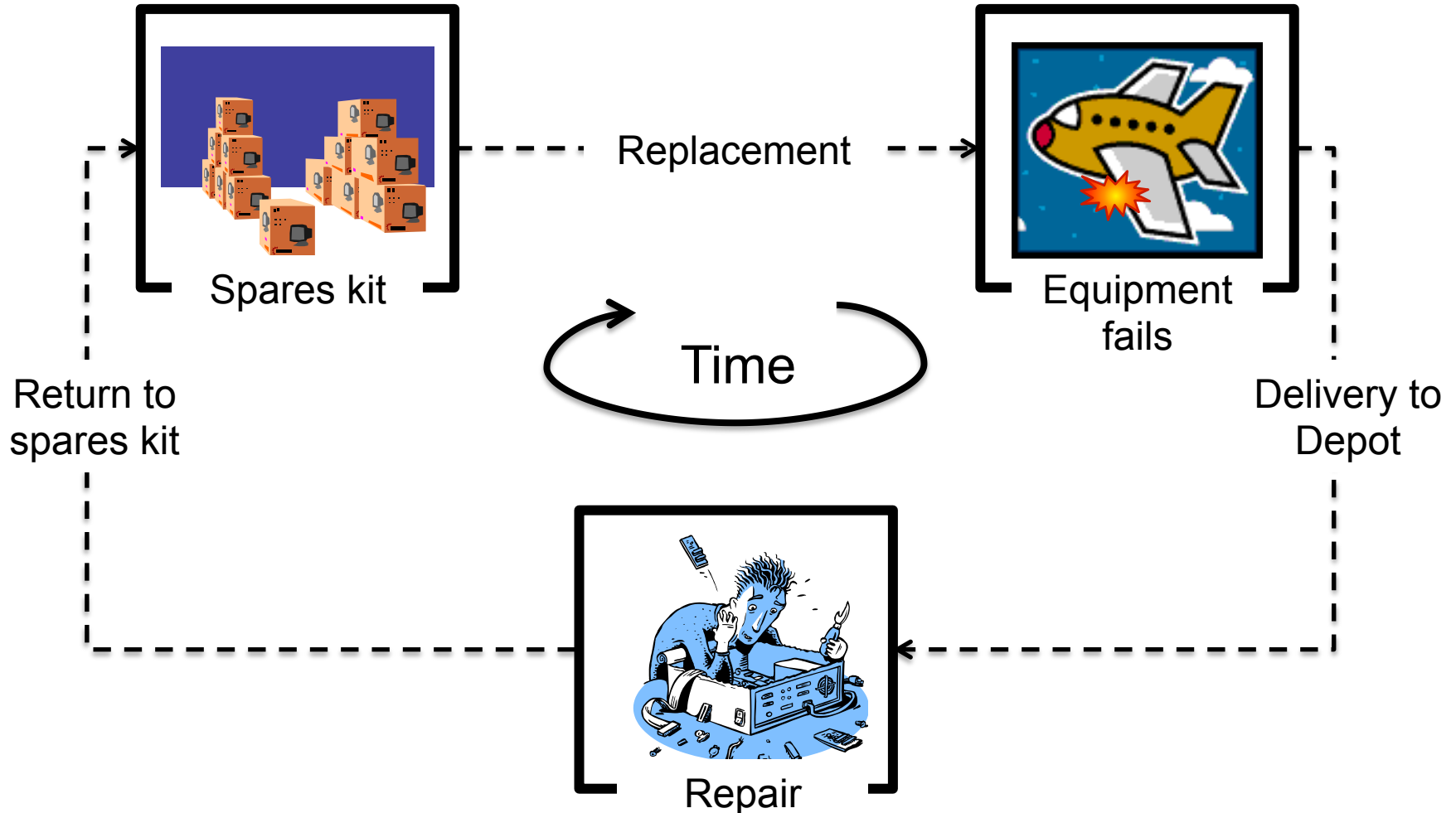

In reality this is what you get!

**Picture subject to
copyright will be included
in presentation**

Often we use a 'product' attribute to estimate cost

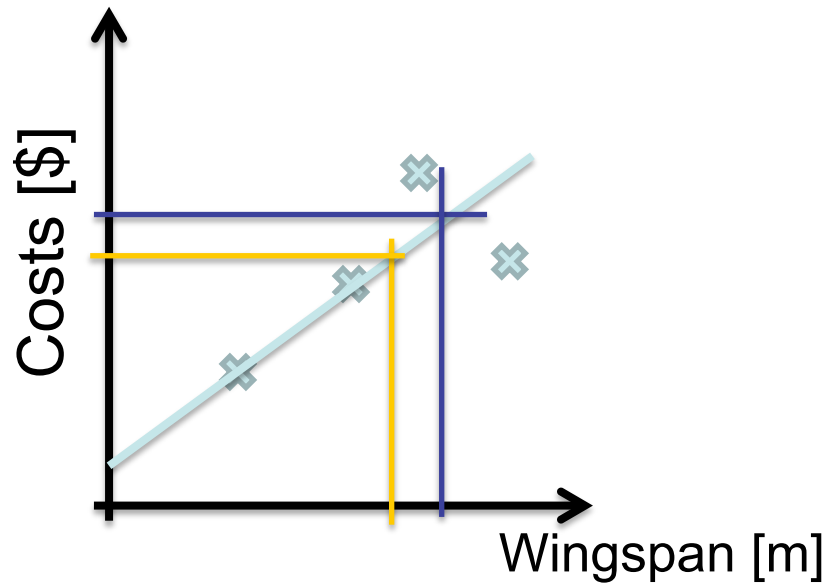

Or detailed bottom-up/build-up approach

PSS

Aircraft availability provision

Picture subject to copyright

© BAE Systems 2012

Top-Down

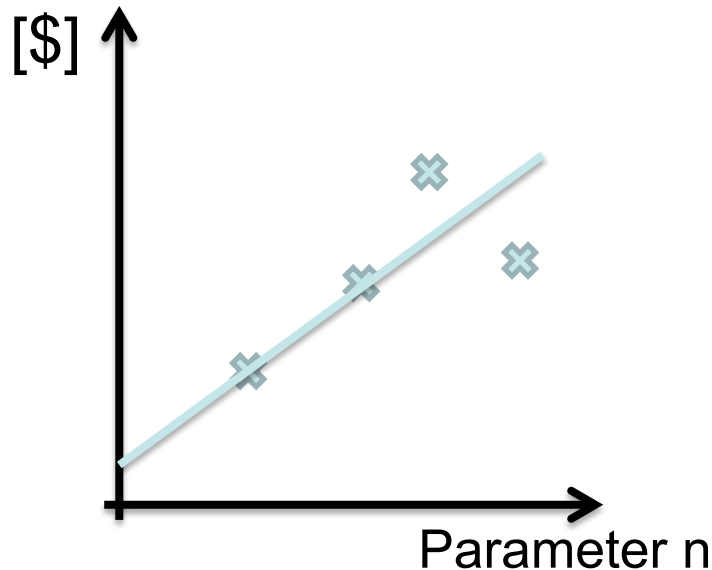

Bottom-up

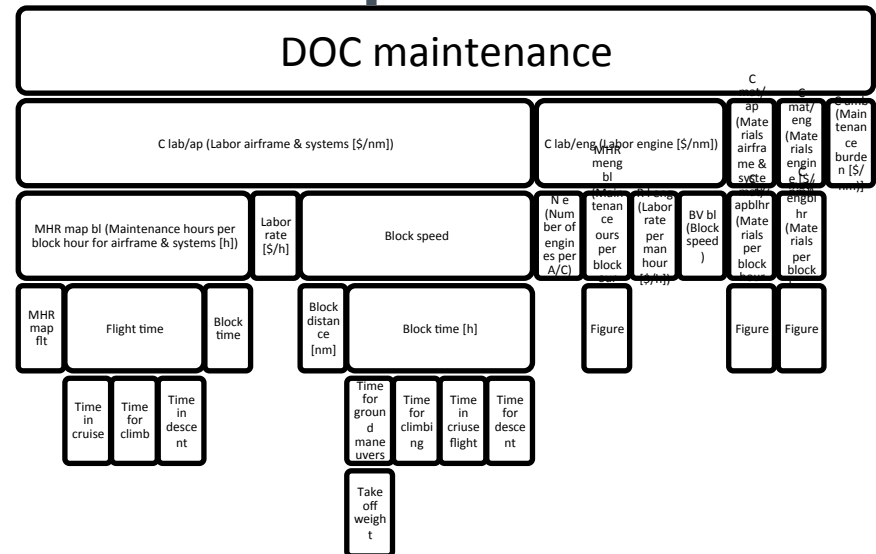

Derived from: Roskam, Jan (1990): Airplane Design: Part VIII (Part 8). Airplane Cost Estimation: Design, Development, manufacturing, and Operating. 8 volumes. Lawrence, Kansas, USA

Top-down & bottom-up are not always helpful!

Miró

Chant Du Rossignol à

minuit et la pluie matinale

*(The Nightingale's Song at Midnight and
the Morning Rain)*

Copyright pictures

Wehrli, Ursus (2004): Kunst aufräumen. 1st ed. [Zürich], [Frankfurt
a.M.: Kein und Aber; Eichborn].

Top-Down

Bottom-up

SYSTEMS APPROACH FROM CONCEPT TO END OF LIFE

Different perspectives – so look at the system

Concepts

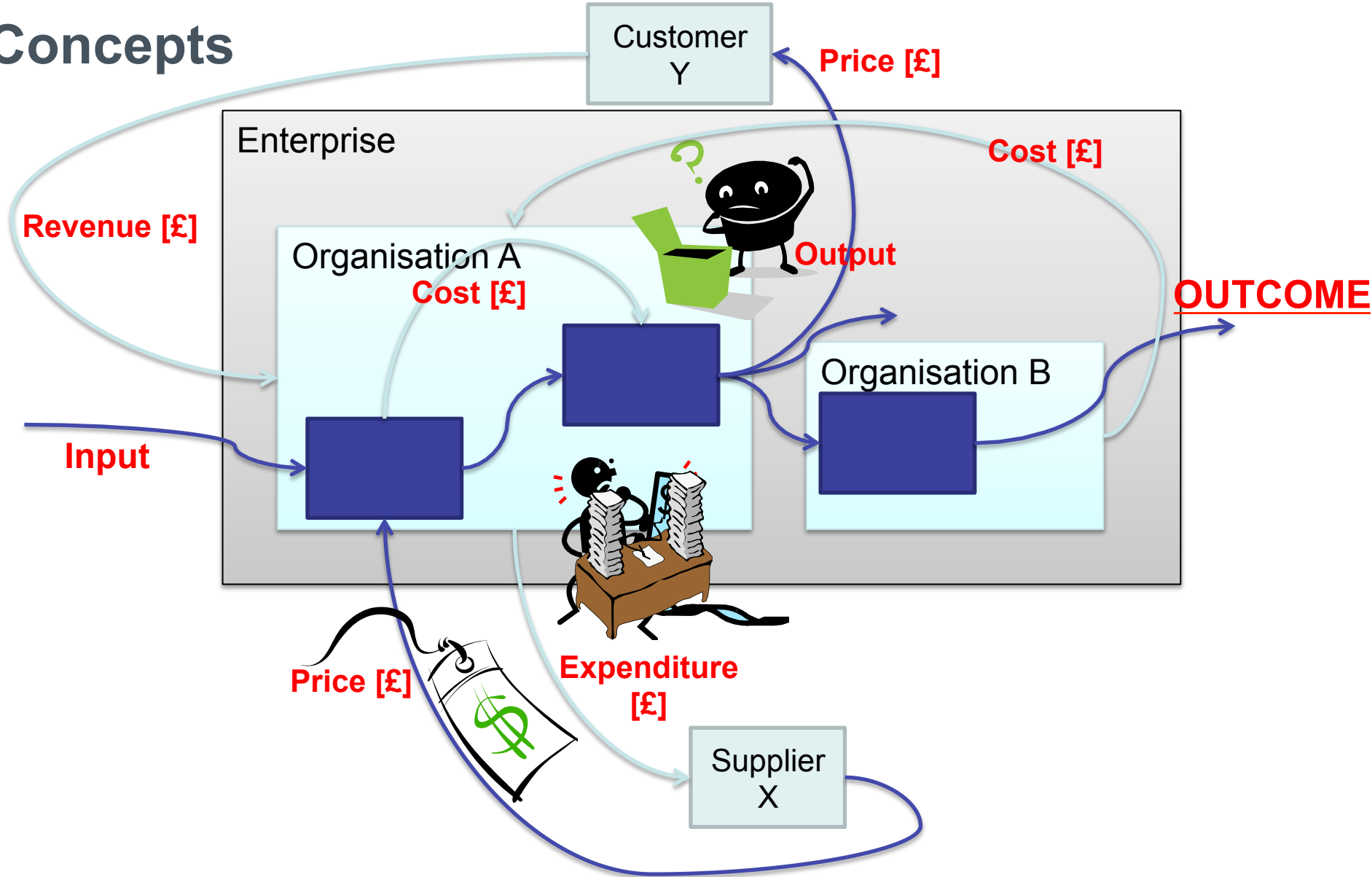

Different perspectives on cost

Watchkeeper example*



<http://www.askamathematician.com/wp-content/uploads/2012/02/black-hole-star-accretion.jpg>

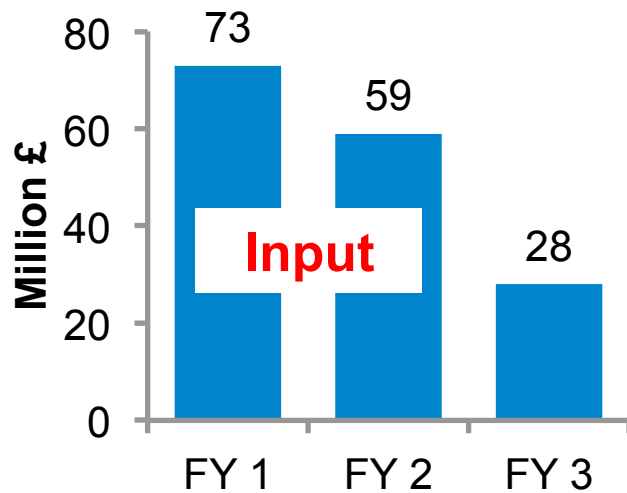

■ Planned annual expenditure

Output

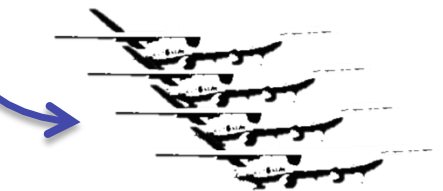

£ 0.34 million/each
(54 UAVs)

*Hoyle, Craig (2013): UK reveals expenditure on delayed Watchkeeper programme. Flightglobal (Flight International). Available online at <http://www.flightglobal.com/news/articles/uk-reveals-expenditure-on-delayed-watchkeeper-programme-380779/>, checked on 1/8/2013.

Different perspectives on cost

Watchkeeper example

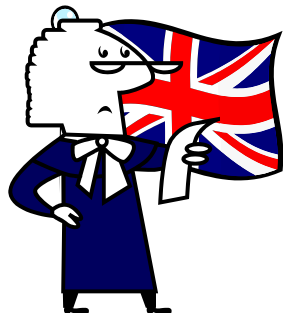

£ 160 million
[2013 - 2016]

Input

£ 61.3 million
[Sept. 2010 - Jan. 2013]



Watchkeeper program



Hermes 450



Outcome

Deliver intelligence,
surveillance, target acquisition
and reconnaissance services
in Afghanistan

Comparison – Watchkeeper example

	Cost is an intrinsic product property	Cost results from cost drivers	Cost is an emergent property
Delivery	A UAV design.	A certified UAS.	Tactical intelligence.
Origin of costs	Wing span or weight of the individual UAV.	Extended time for certification.	Activities necessary before, during and after deployment.
Possibilities to take action	Reduce UAV size.	Expedite certification.	Manage activities.

Delivering an outcome = deliver a system

Purposes of cost estimation

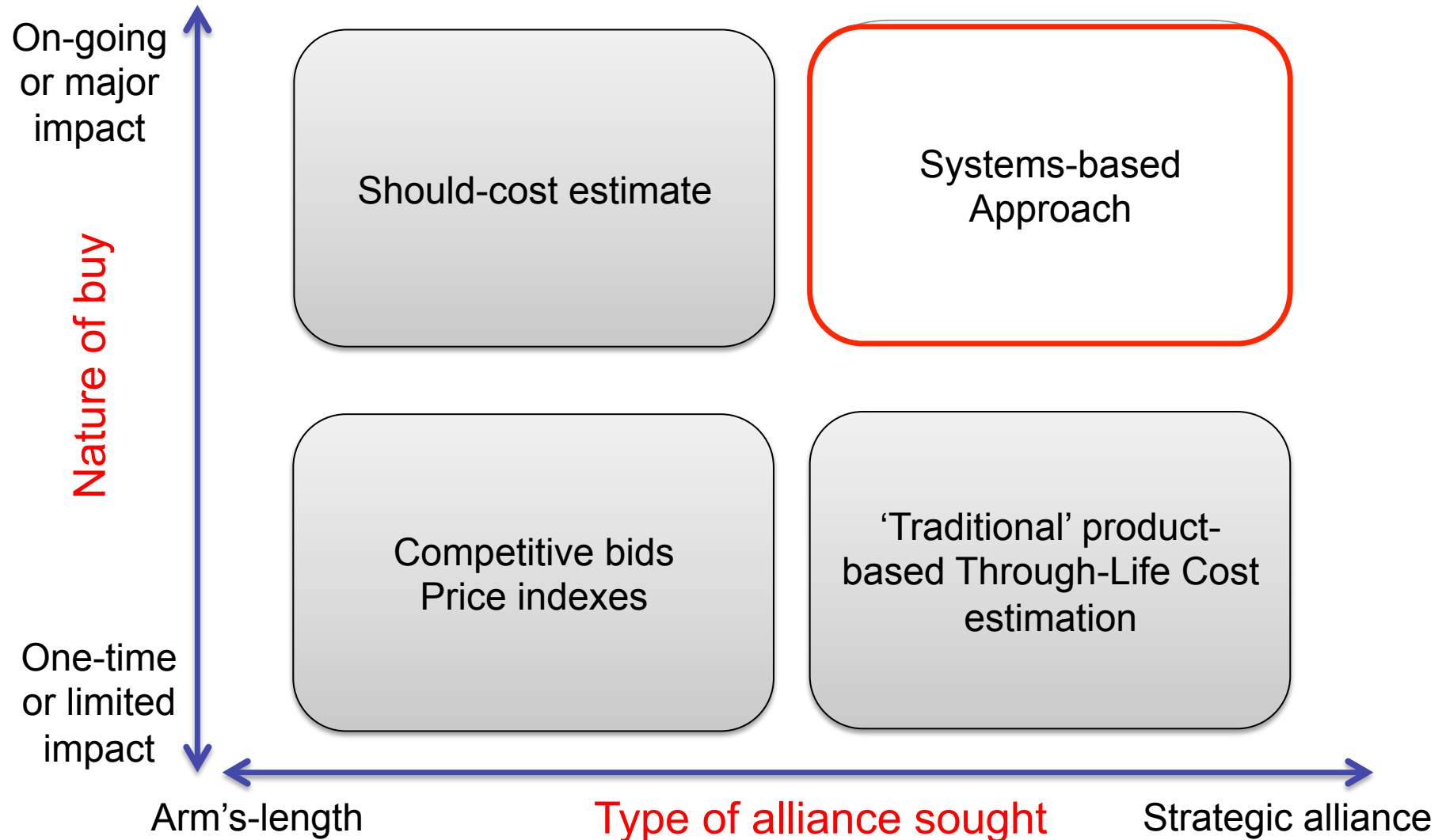

Using a systems approach

System Identification:

What is the phenomenon we deal with ?

Process mapping

IDEF0 & FRAM

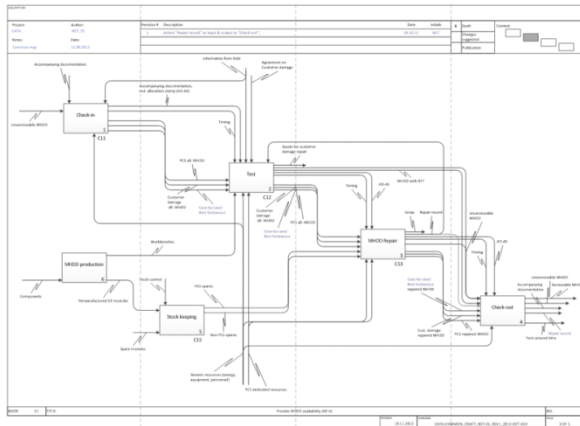

Interviews

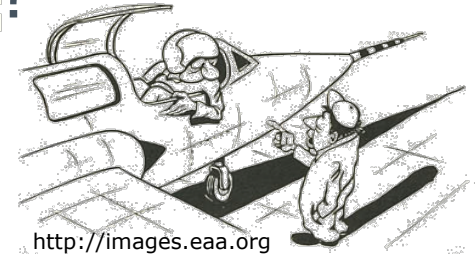

Insight from people
In the system

Document &
reliability analysis



Review repair reports &
appropriate data

Copyright picture

Relevant System: Elements and Relationships

The relevant System: Elements & Relationships

Functions

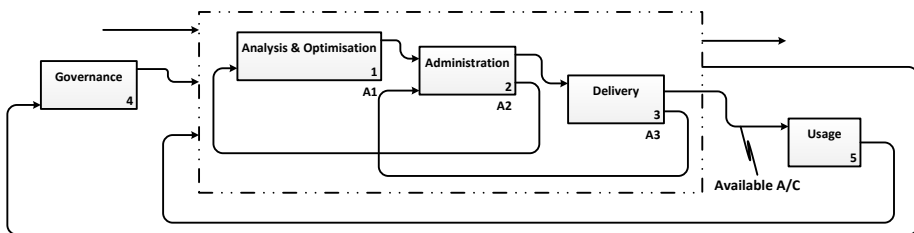

Organisations

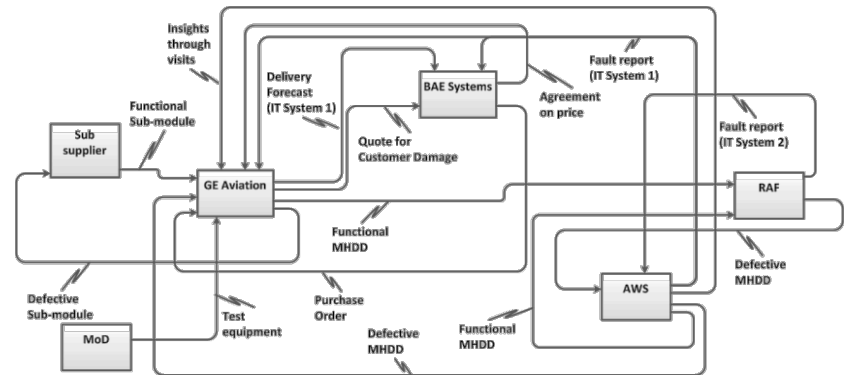

Scenarios

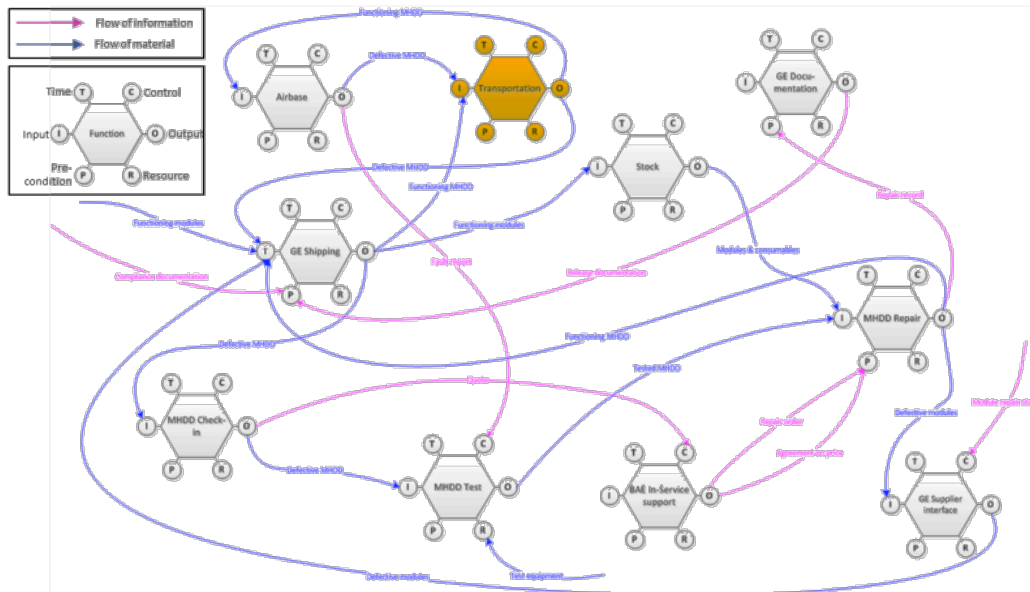

Qualitative and Quantitative Modelling

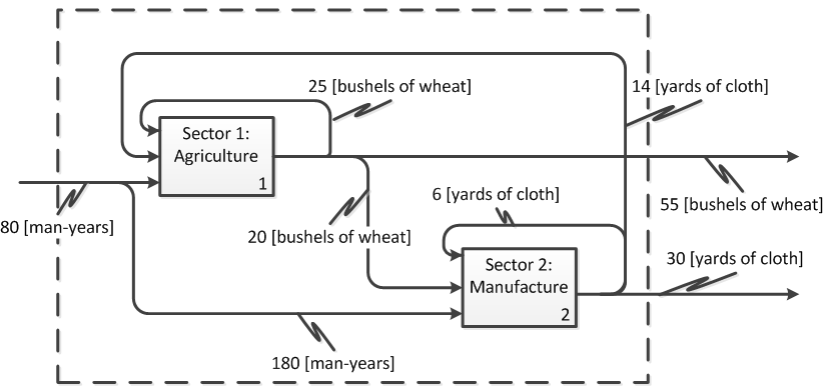

<i>from</i>	<i>into</i>	Activity 1	Activity 2	Delivery (final)	Total output
Output 1		25	20	55	100
Output 2		14	6	30	50
Resources		80	180		

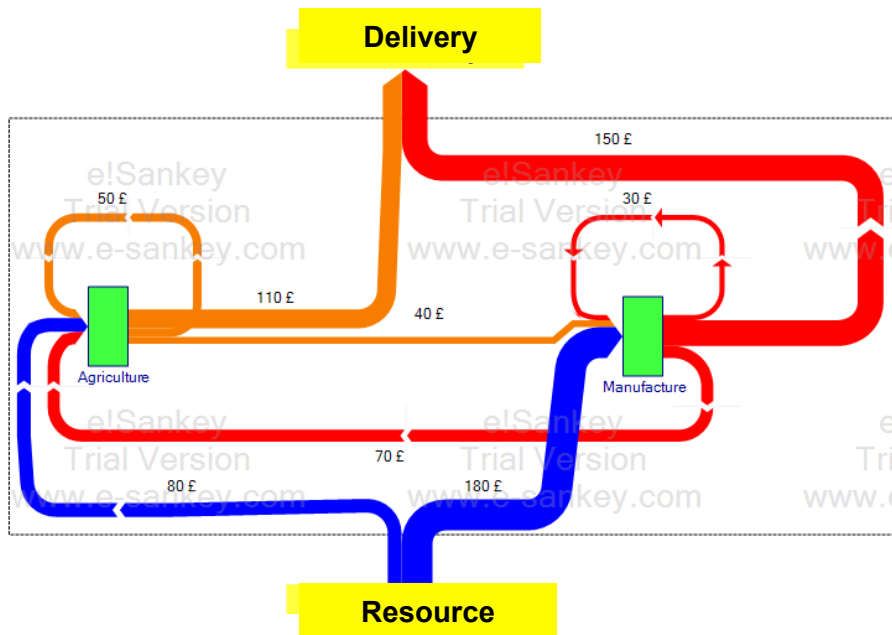

$$x = (I - A)^{-1}y$$

$$p^T = v^T(I - A)^{-1}$$

Estimation of the unit cost of each output delivered

Example results and context

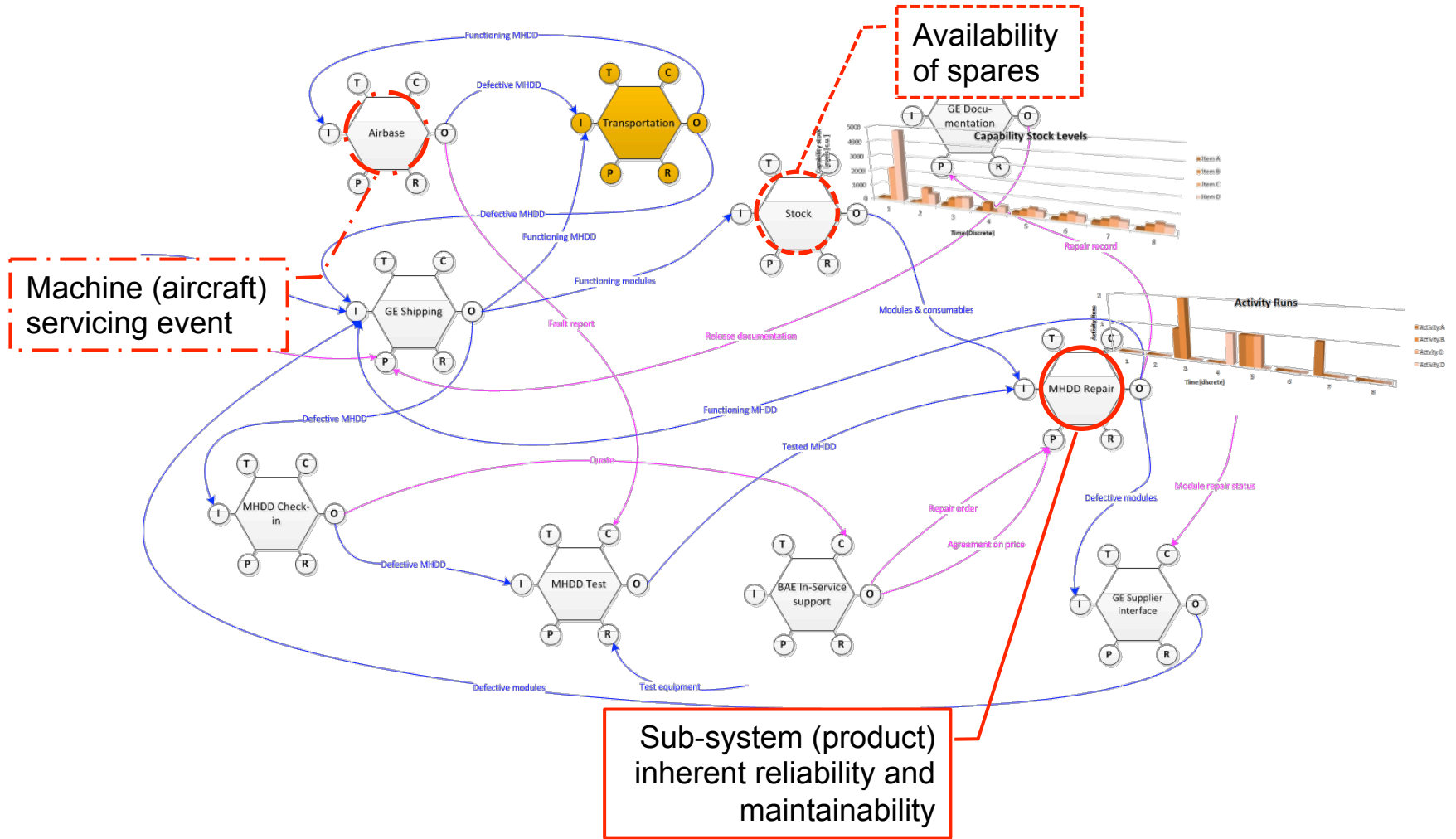

Prevent Local Optimisation

Local optimisation on “servicing events”

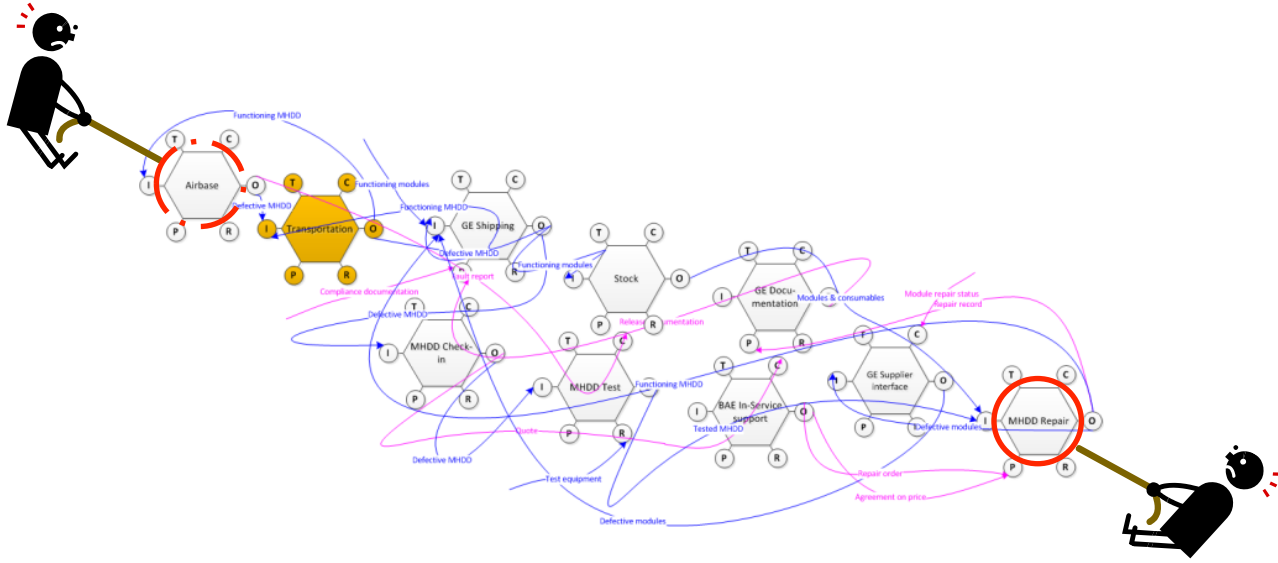

Local optimisation on “repair events”

TRANSFER APPROACH TO WATER SECTOR

From defence to water sector ...and beyond?

Outcome-based approach in water sector

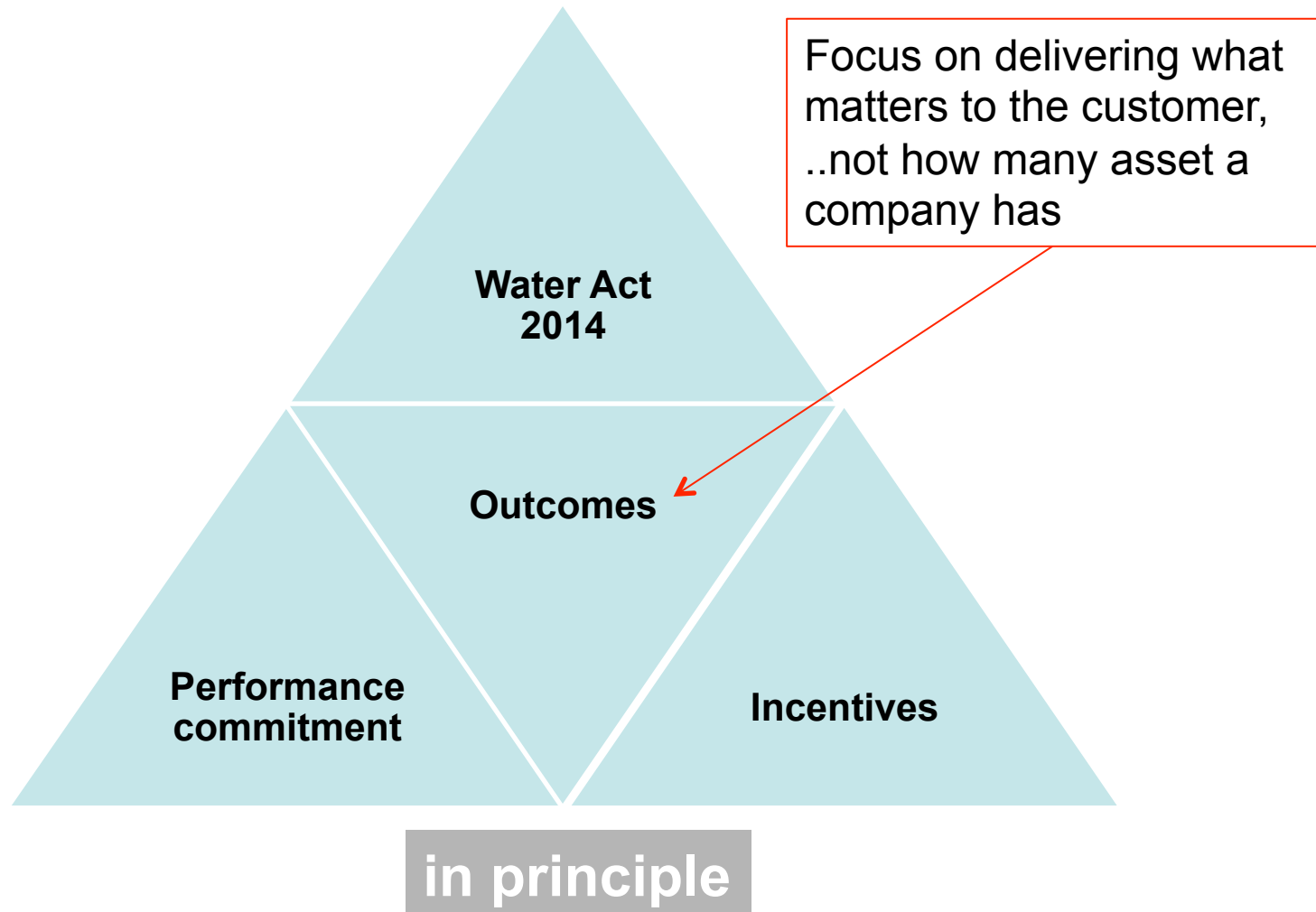

From defence to water sector ...and beyond?

Outcome-based approach in water sector

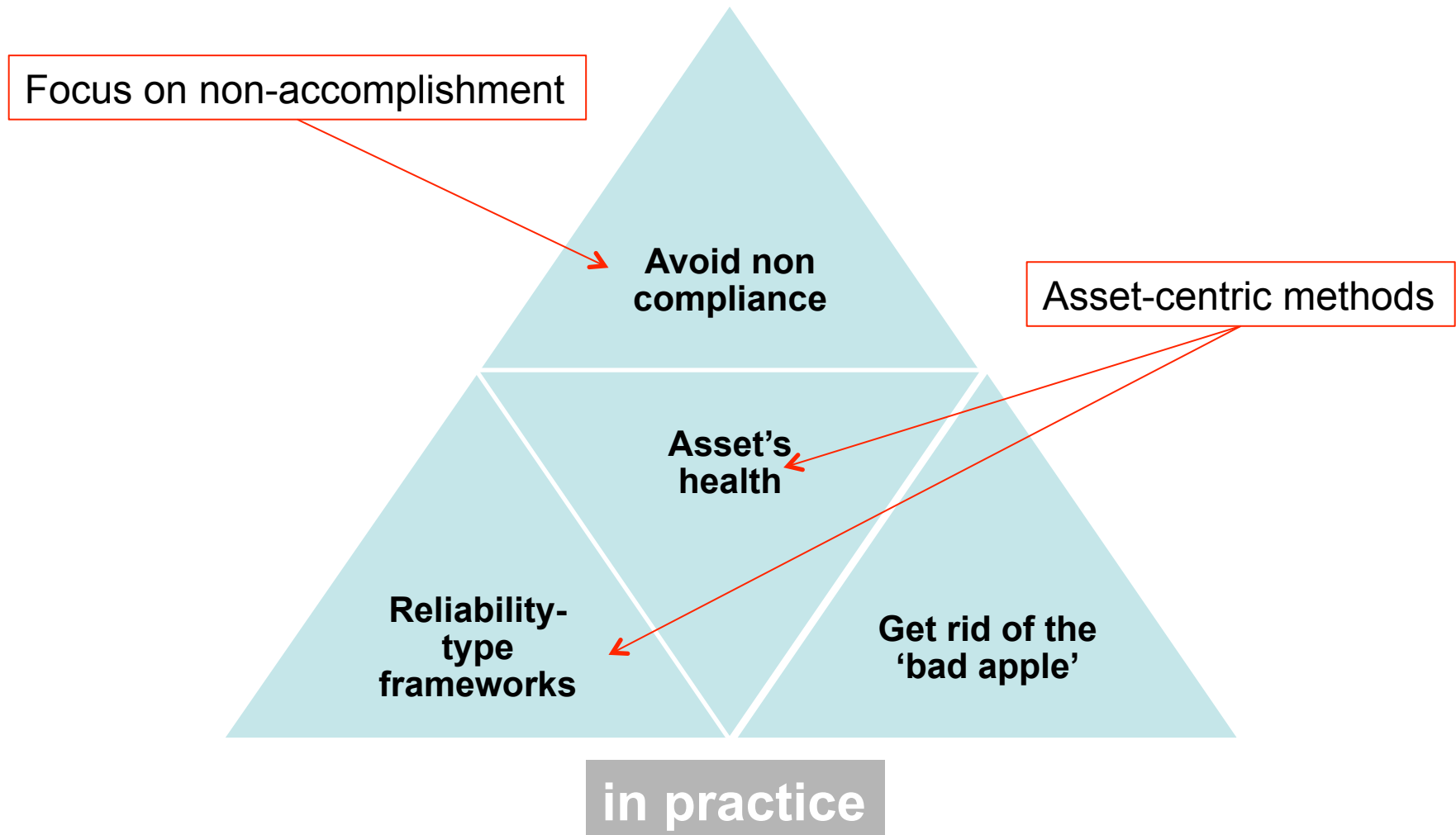

From defence to water sector ...and beyond?

Outcome-based approach in water sector



Source: Wessex Water Plc



Source: Wessex Water Plc

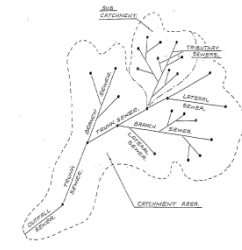

Source: Wessex Water Plc

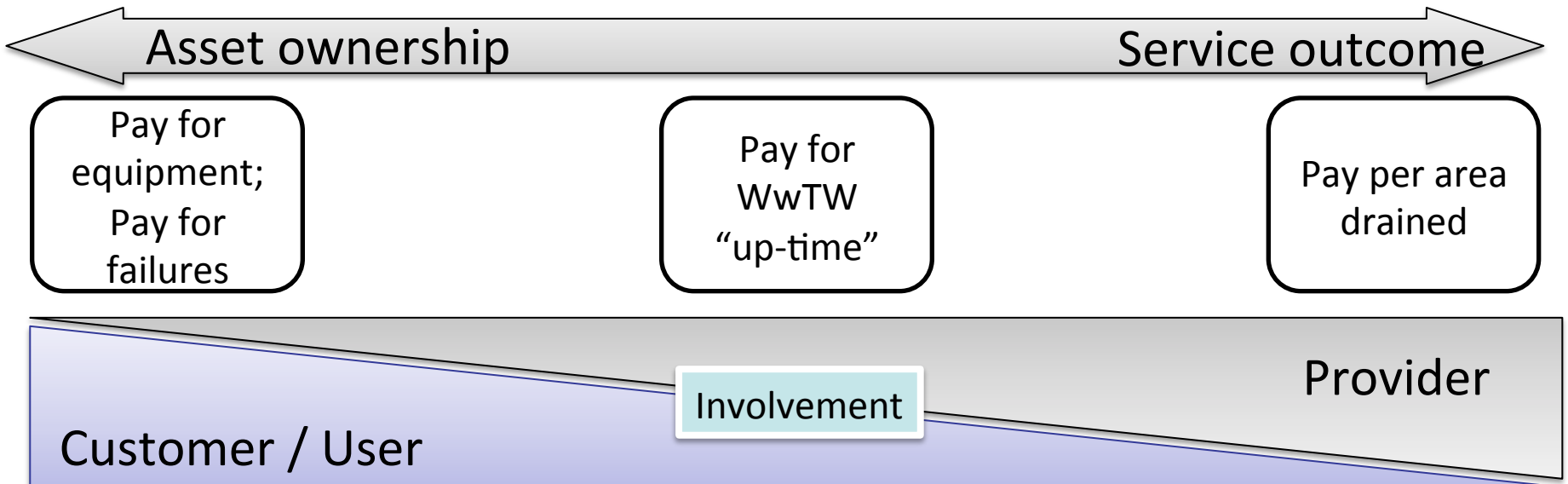

From defence to water sector ...and beyond?

Outcome-based approach in water sector



Source: Wessex Water Plc



Source: Wessex Water Plc

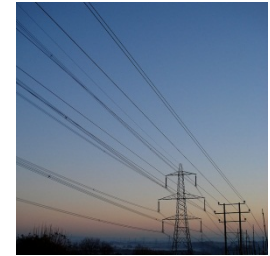

Source: MS Clipart

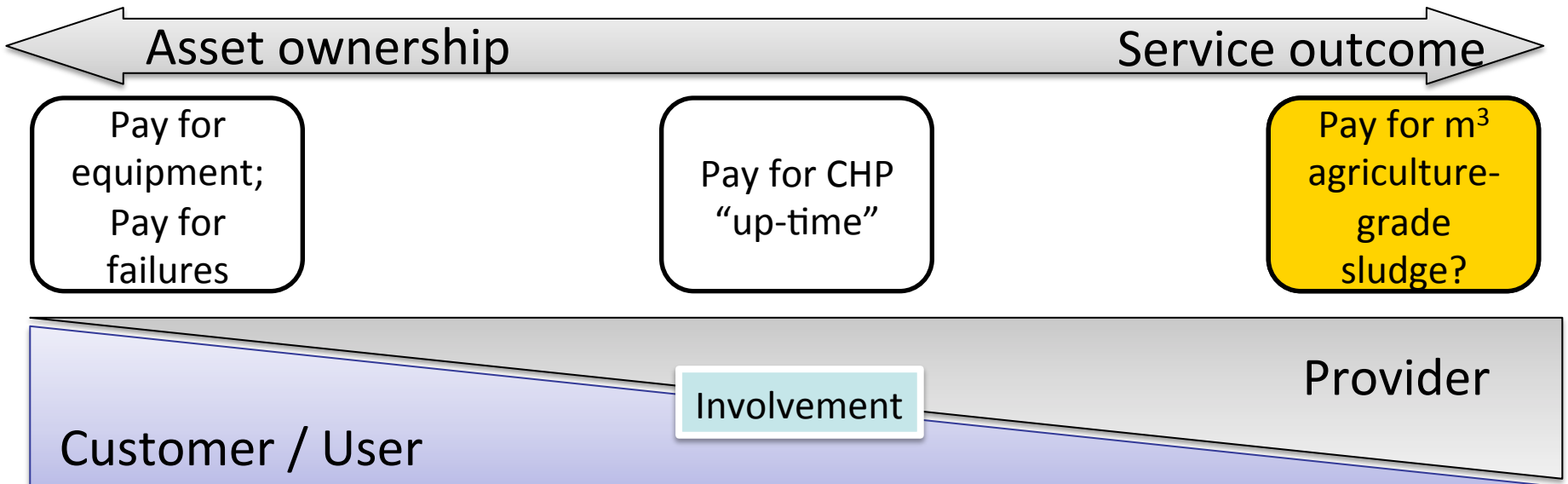

Our approach

Visualisation: water-related physical flows

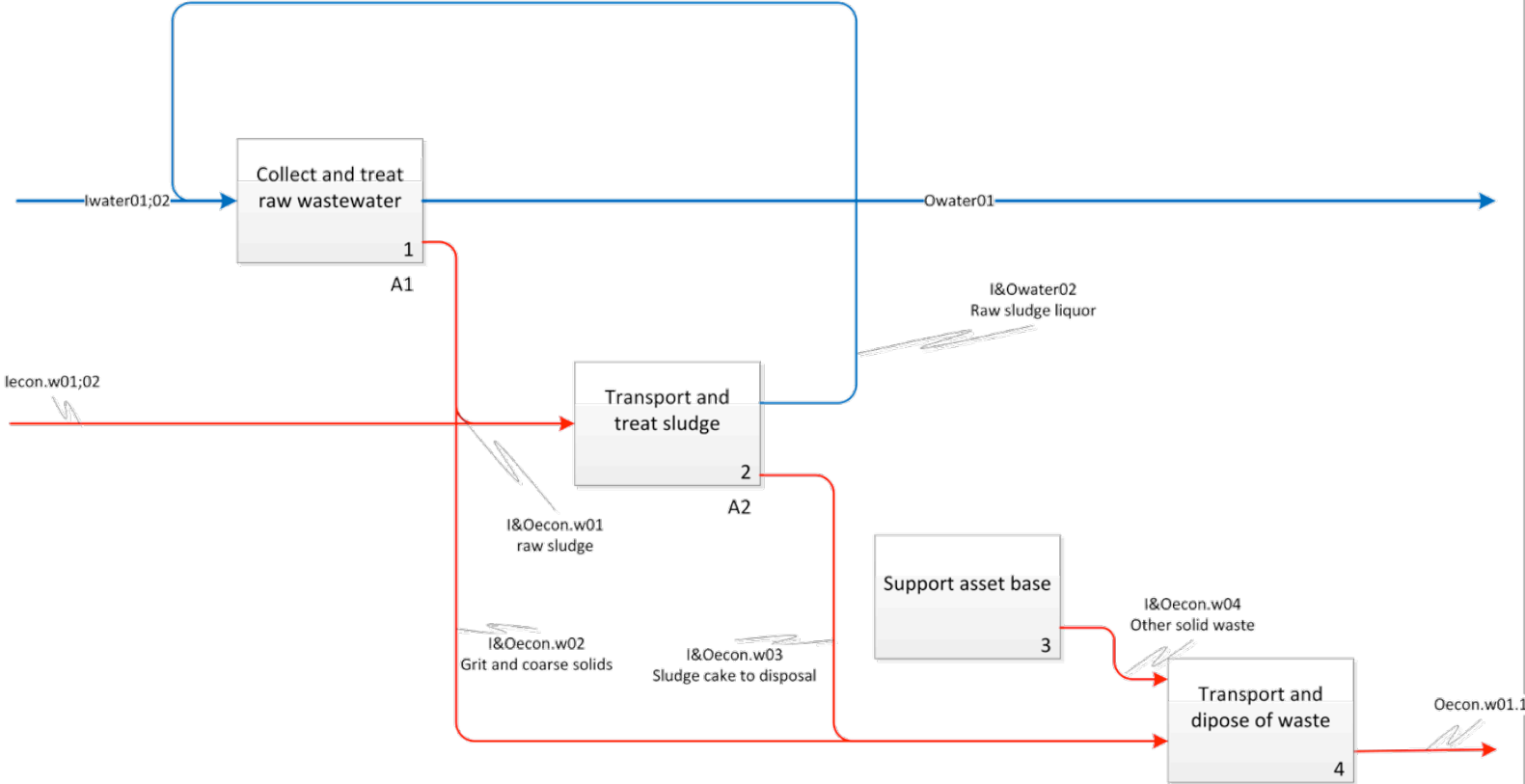

Our approach

Visualisation: water-related physical flows

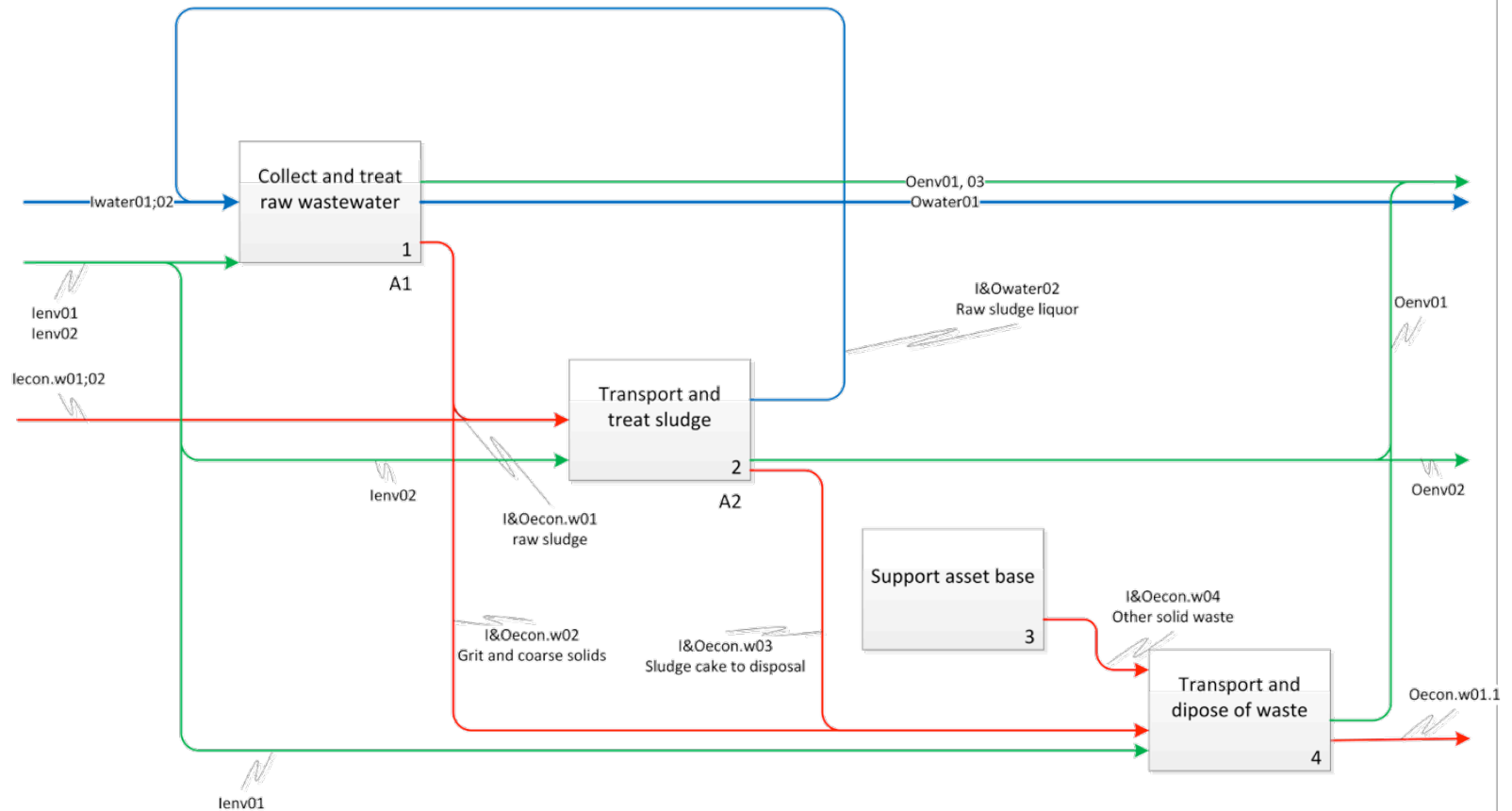

Our approach

Visualisation: economic flows

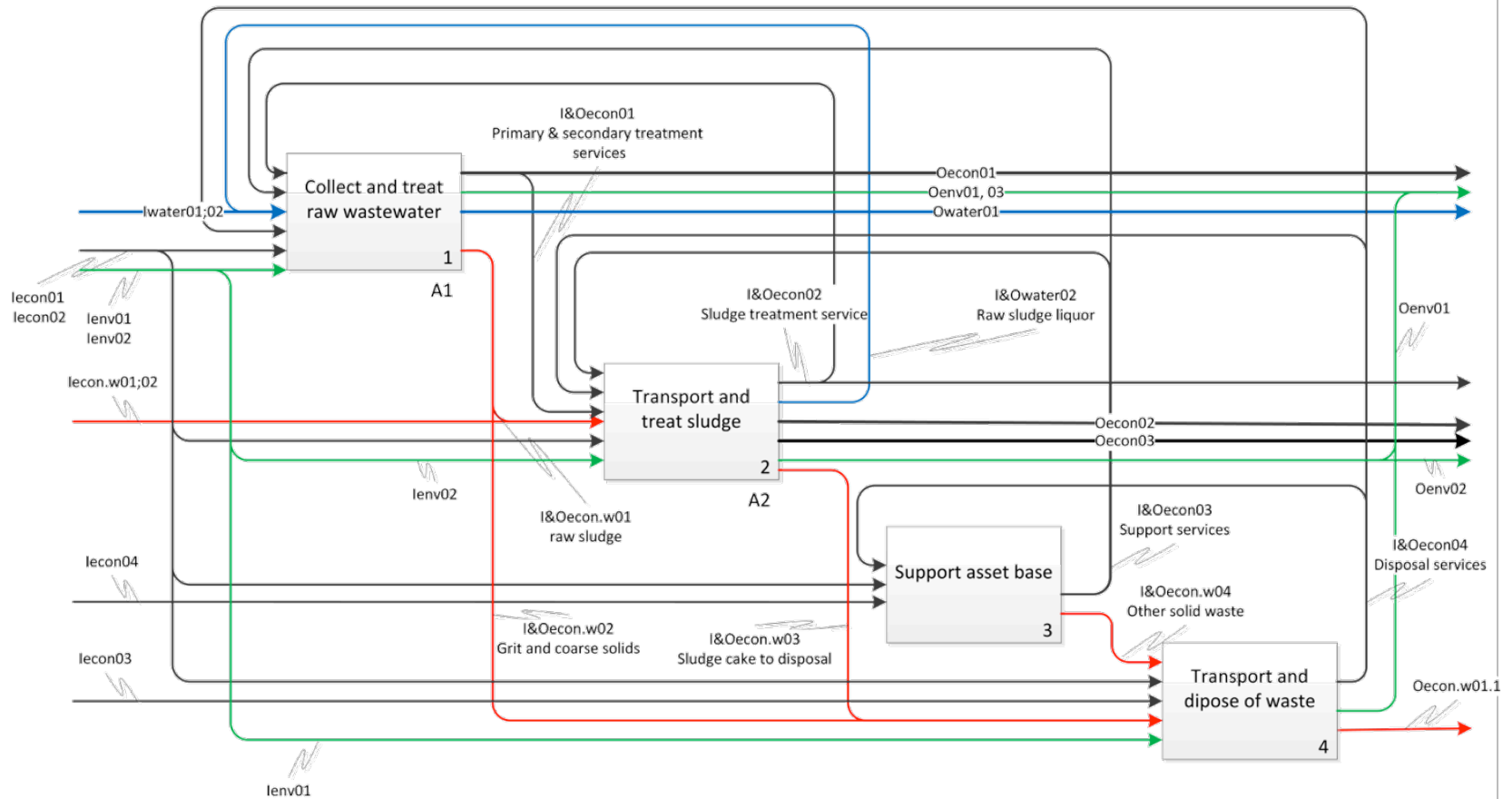

Our approach

Visualisation: enabling conditions

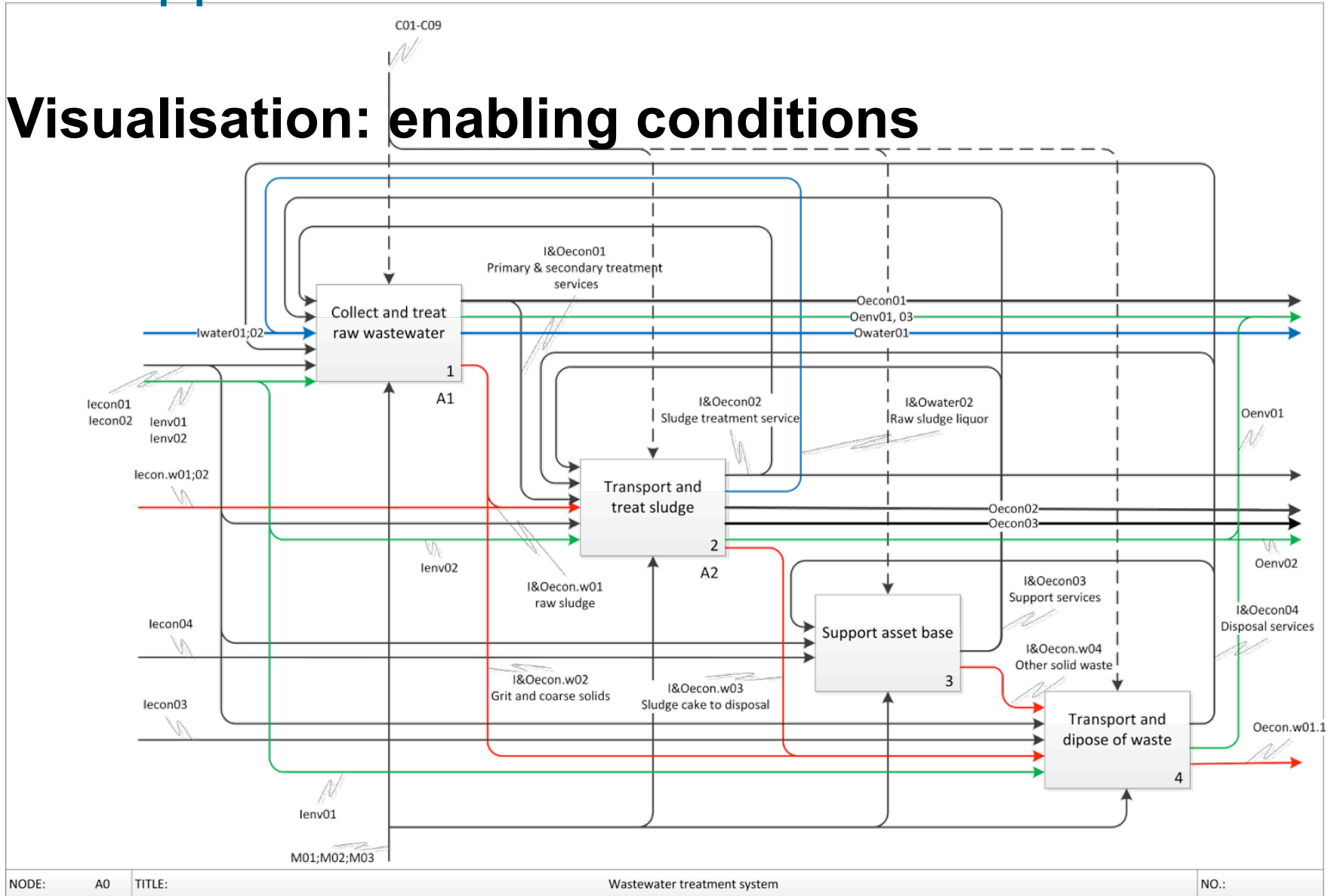

NODE: A0

TITLE:

Wastewater treatment system

NO.:

Suggested approach

Industrial Example

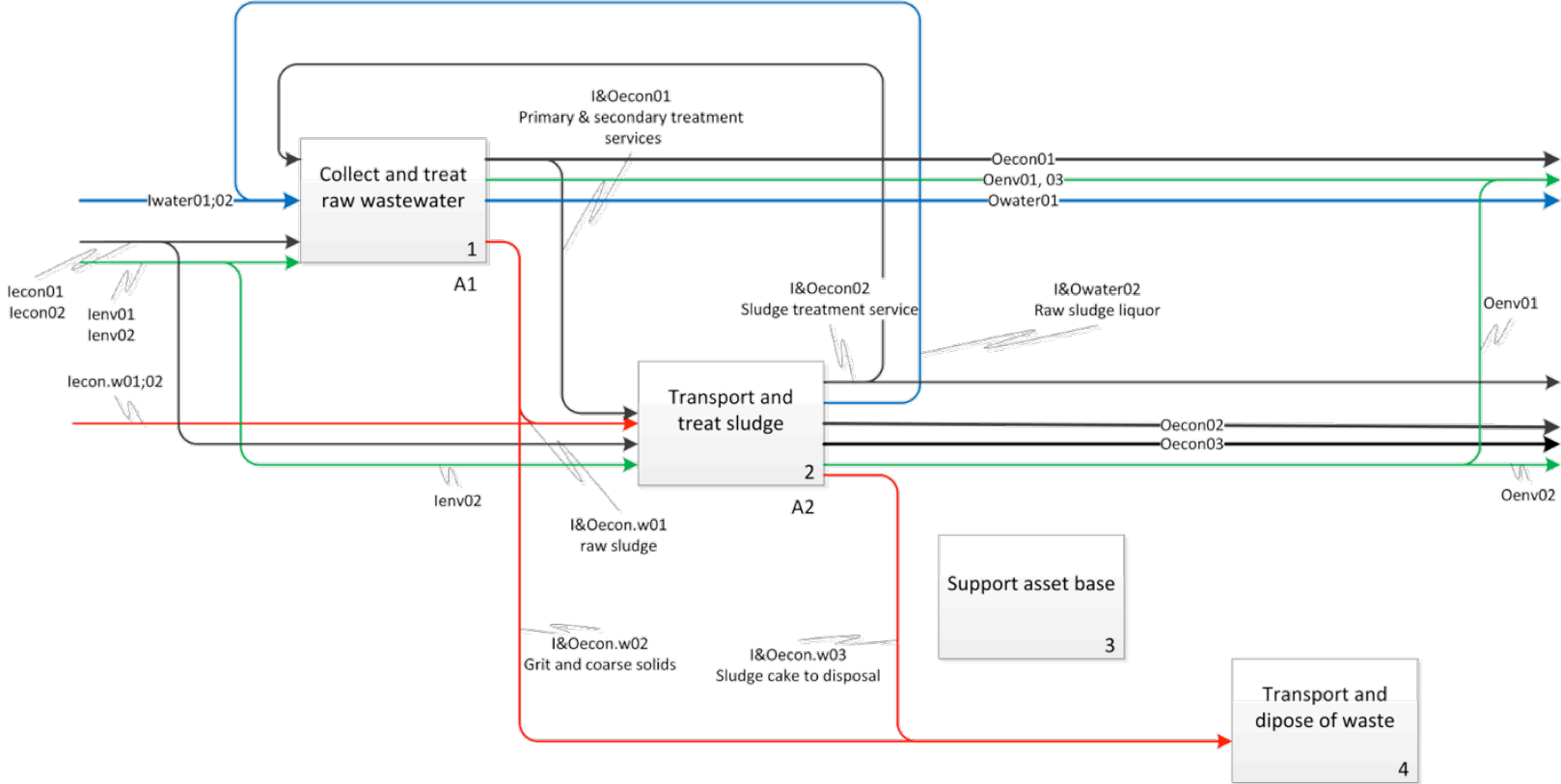

Application

Material-flow view

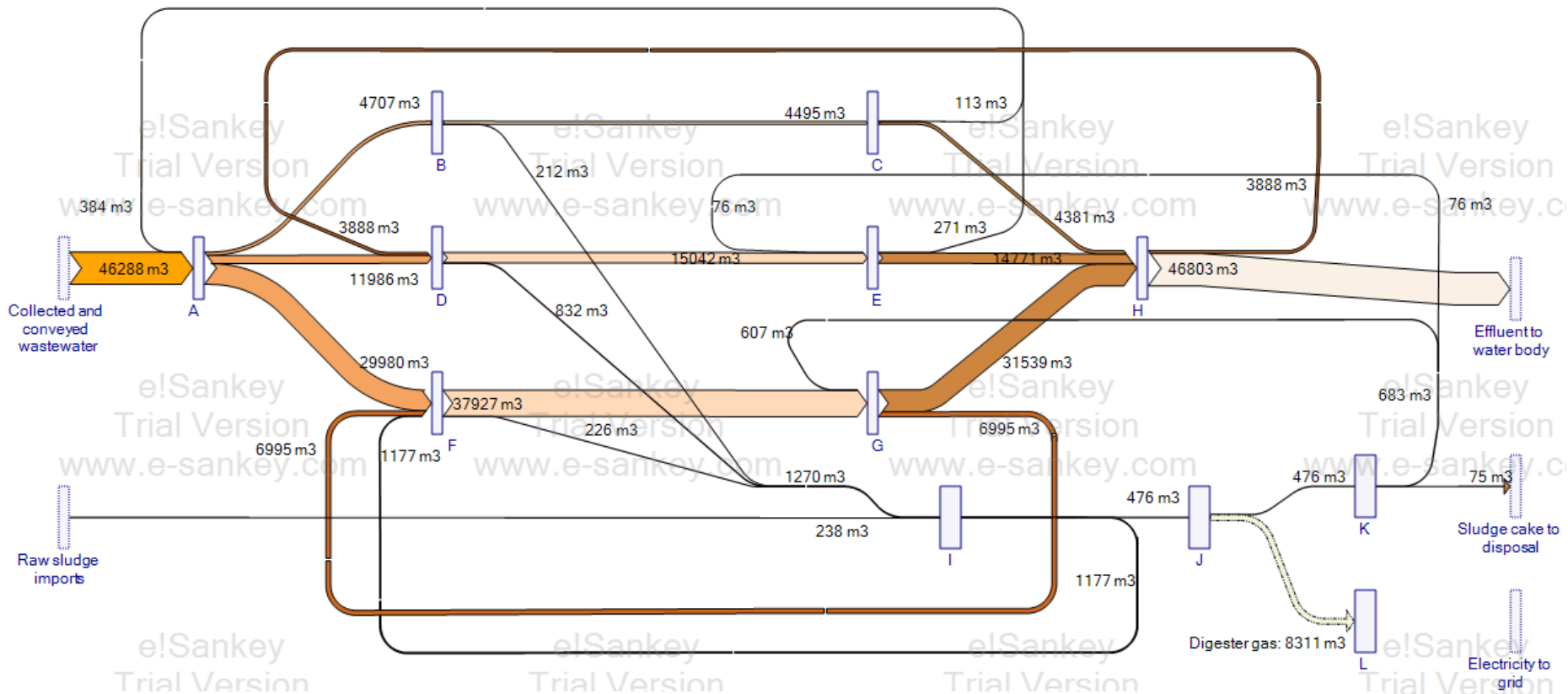

- A: Screen and de-grit raw wastewater
- B: Remove solids through quiescent gravity settling - Western works
- C: Remove organic matter by Activated Sludge - Western works
- D: Remove solids through quiescent gravity settling - Eastern works
- E: Remove organic matter by Activated Sludge - Eastern works
- F: Remove solids through chemically-assisted primary settlement
- G: Remove organic matter by Biological Aerated Flooded filters - BAFF

- H: Remove nutrients and pathogens
- I: Blend and thicken sludge
- J: Generate digester gas
- K: Dewater and treat liquors
- L: Co-generate heat and power

Application

'Service'-provision view

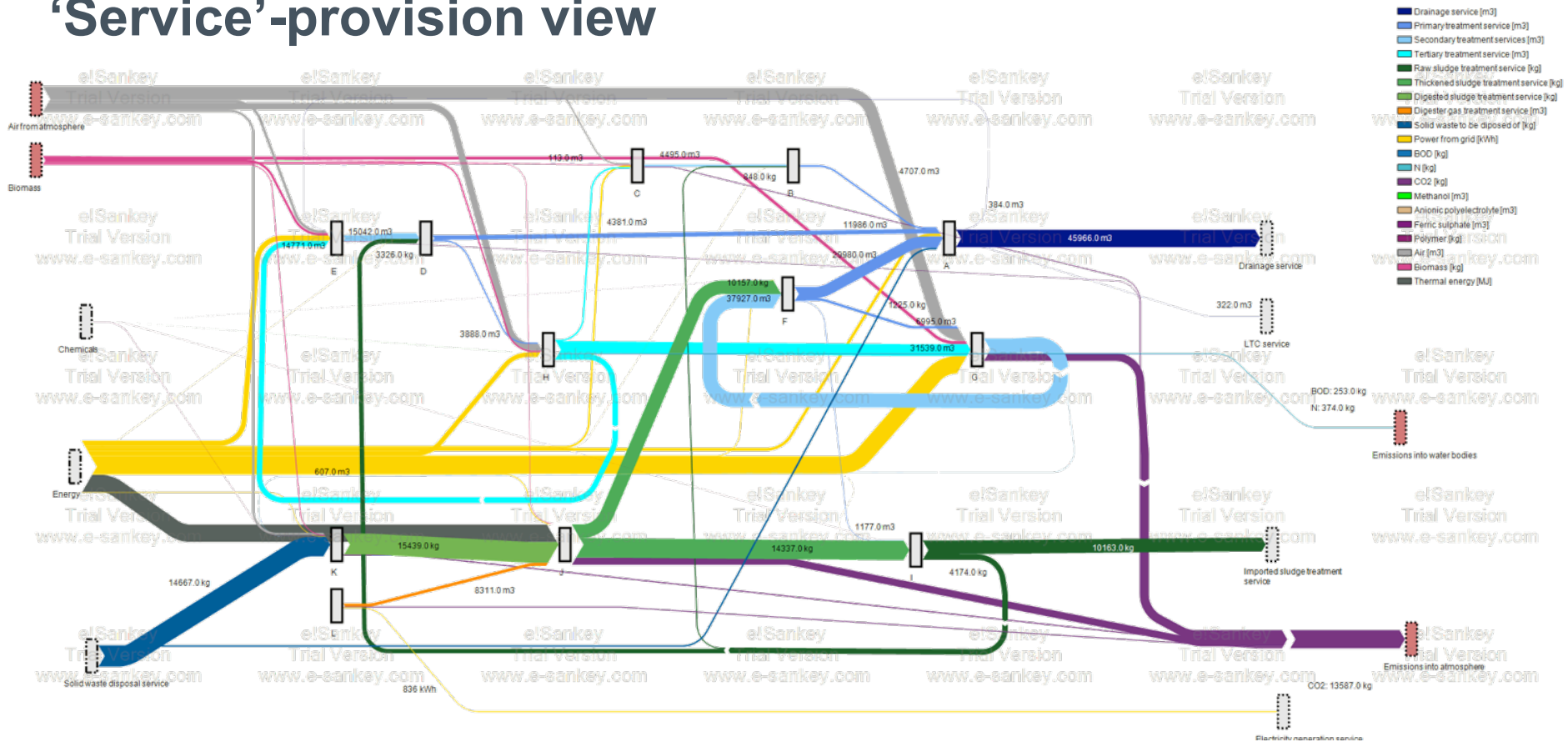

A: Screen and de-grit raw wastewater

B: Remove solids through quiescent gravity settling - Western works

C: Remove organic matter by Activated Sludge - Western works

D: Remove solids through quiescent gravity settling - Eastern works

E: Remove organic matter by Activated Sludge - Eastern works

F: Remove solids through chemically-assisted primary settlement

G: Remove organic matter by Biological Aerated Flooded filters - BAFF

H: Remove nutrients and pathogens

I: Blend and thicken sludge

J: Generate digester gas

K: Dewater and treat liquors

L: Co-generate heat and power

Application

Wastewater component concentration

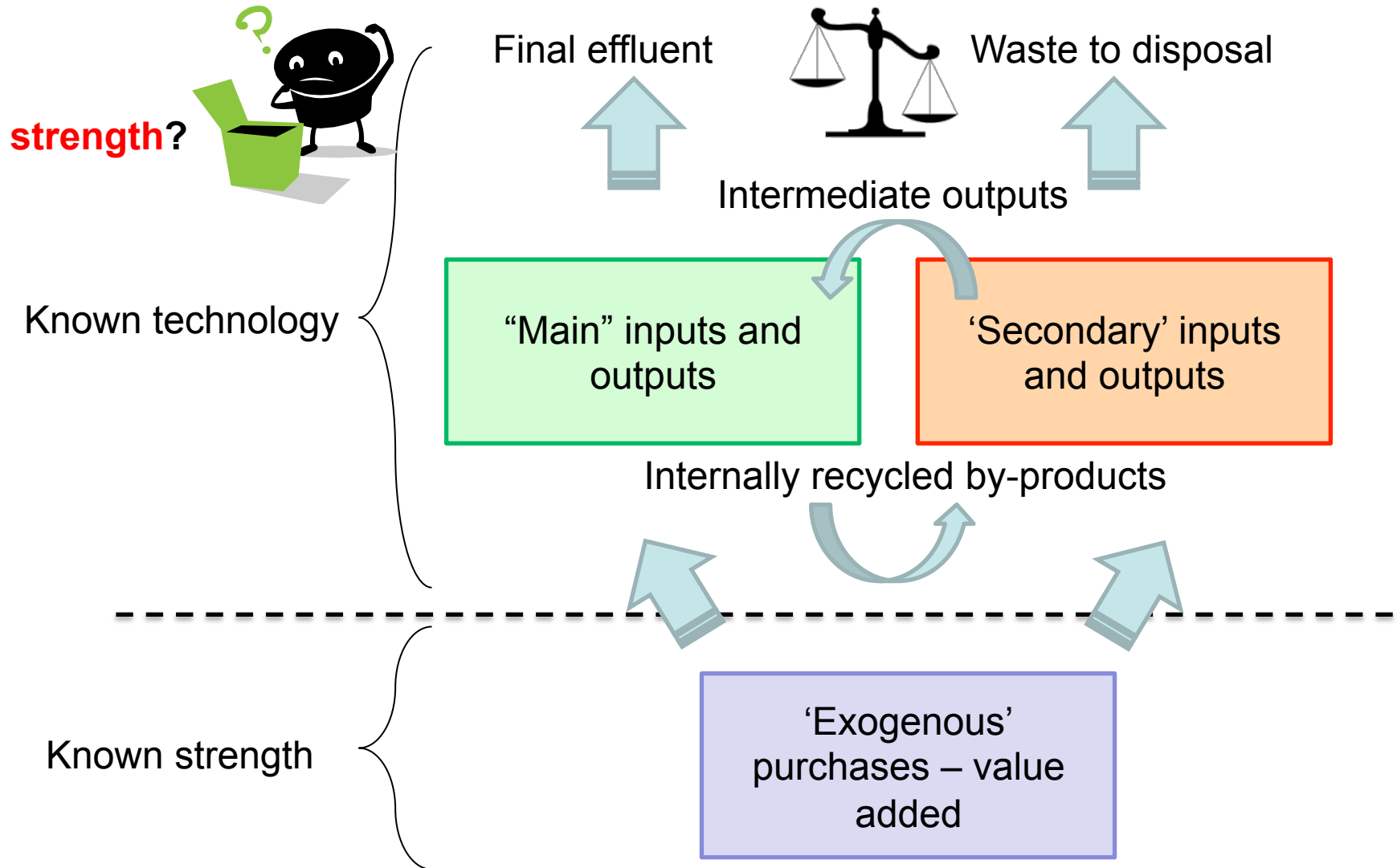

Application

Cost evaluation

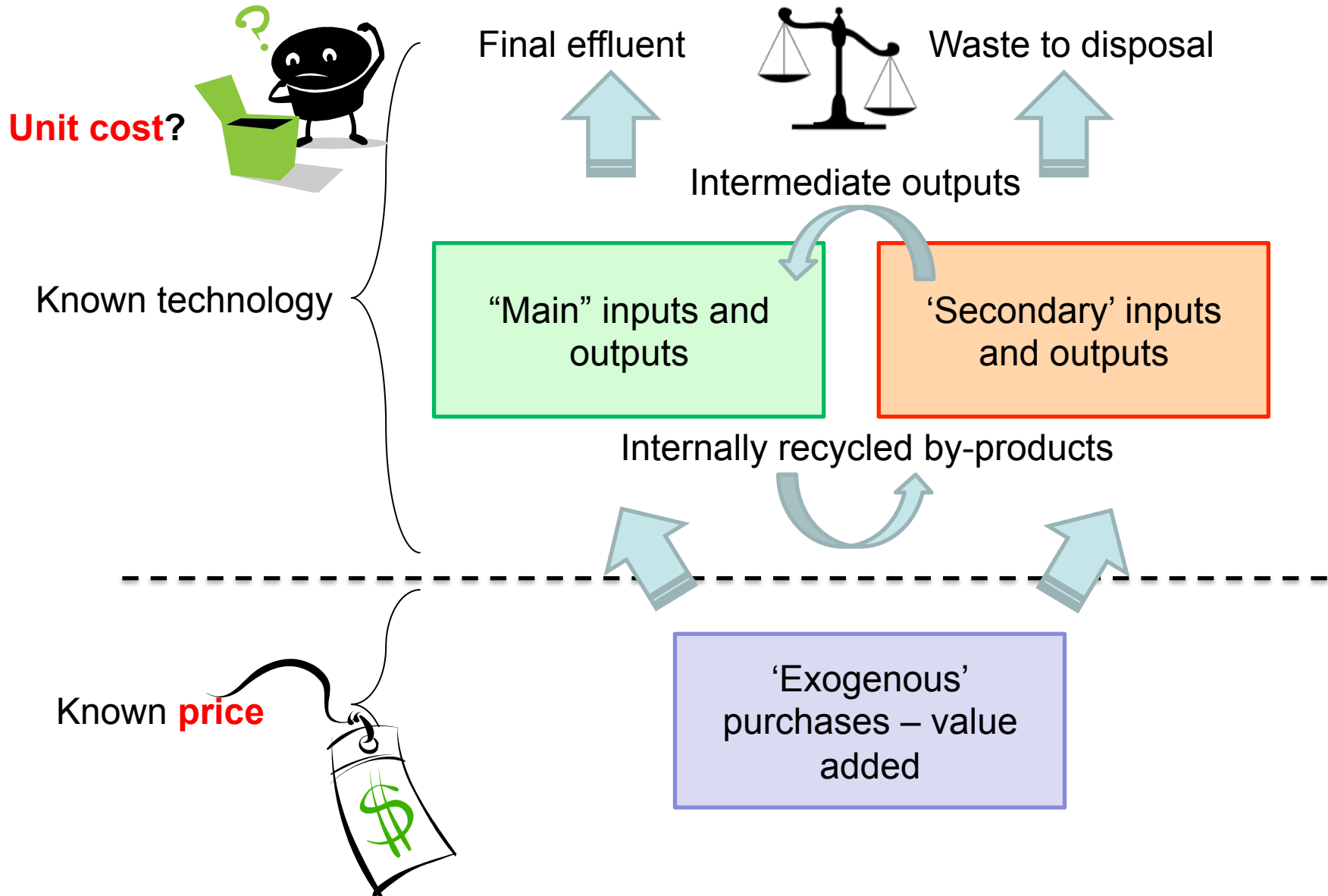

Application

Catchment-level management?

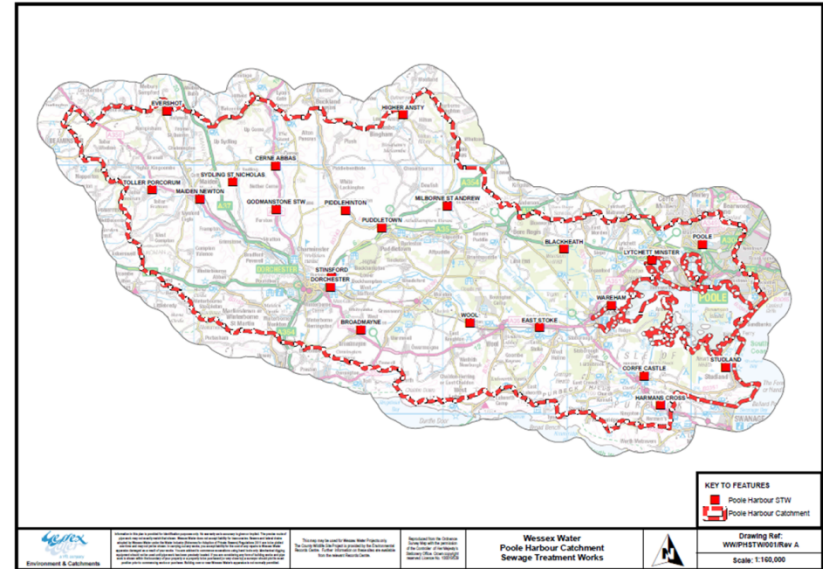
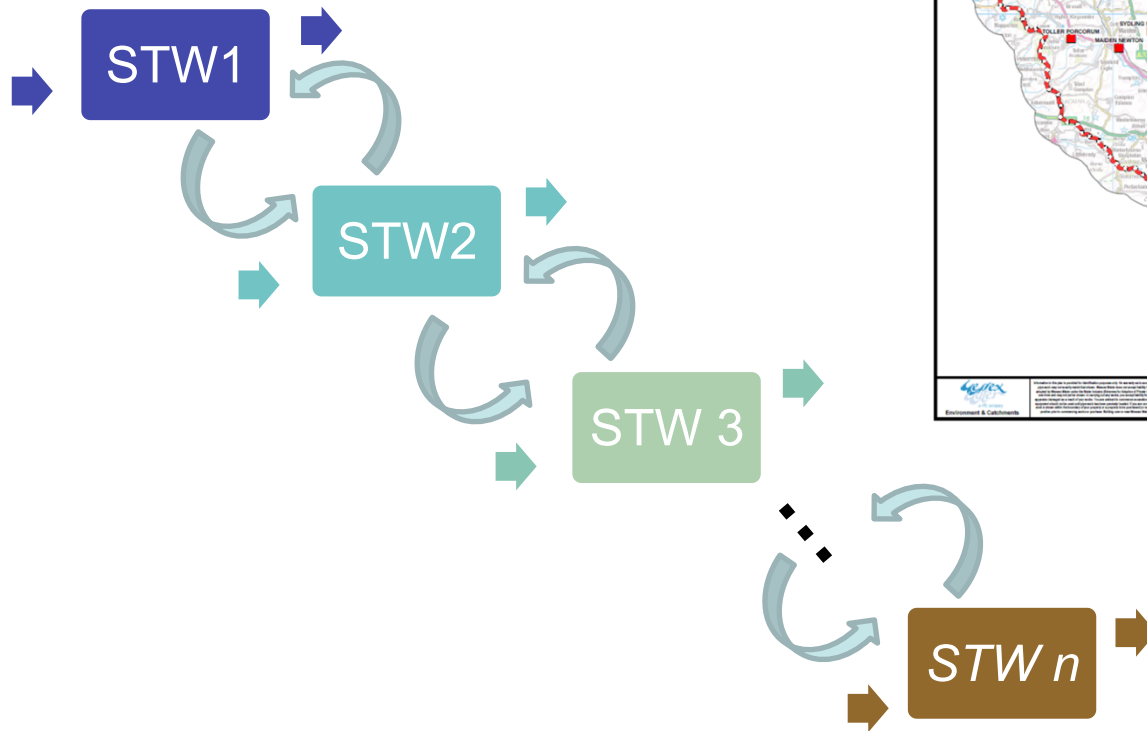

Wrap up

Outcome perspective:
Happening across sectors



Rigorous modelling underpinning multi-faceted performance evaluation

- Service mapping;
- Consistent use of Mass balances;
- Historical data track record

Future research:

- Cross-sectorial applicability?
- Linking conceptual/scientific modelling
- Catchment-level analysis
- Exploit link with sustainability analysis

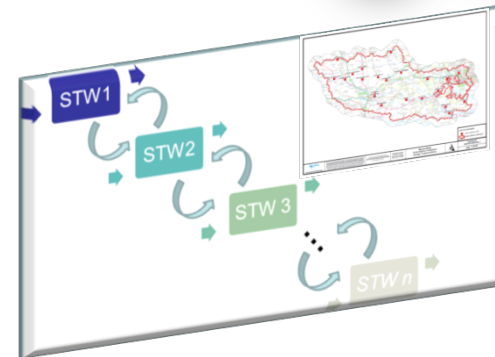
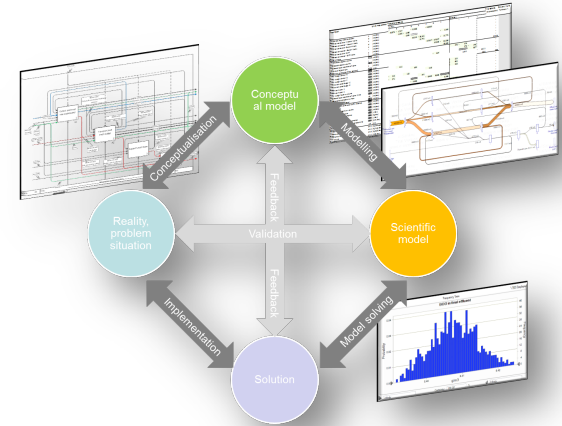

FIFTY SHADES OF GREY WATER



<http://www.defenseprocurementnews.com/>



Source: Wessex Water Plc



<https://commons.wikimedia.org>

Thank you for your attention

LINDA NEWNES

L.B.NEWNES@BATH.AC.UK